

GROUND FLOOR
AREA: 260M²

SCALE : 1/100

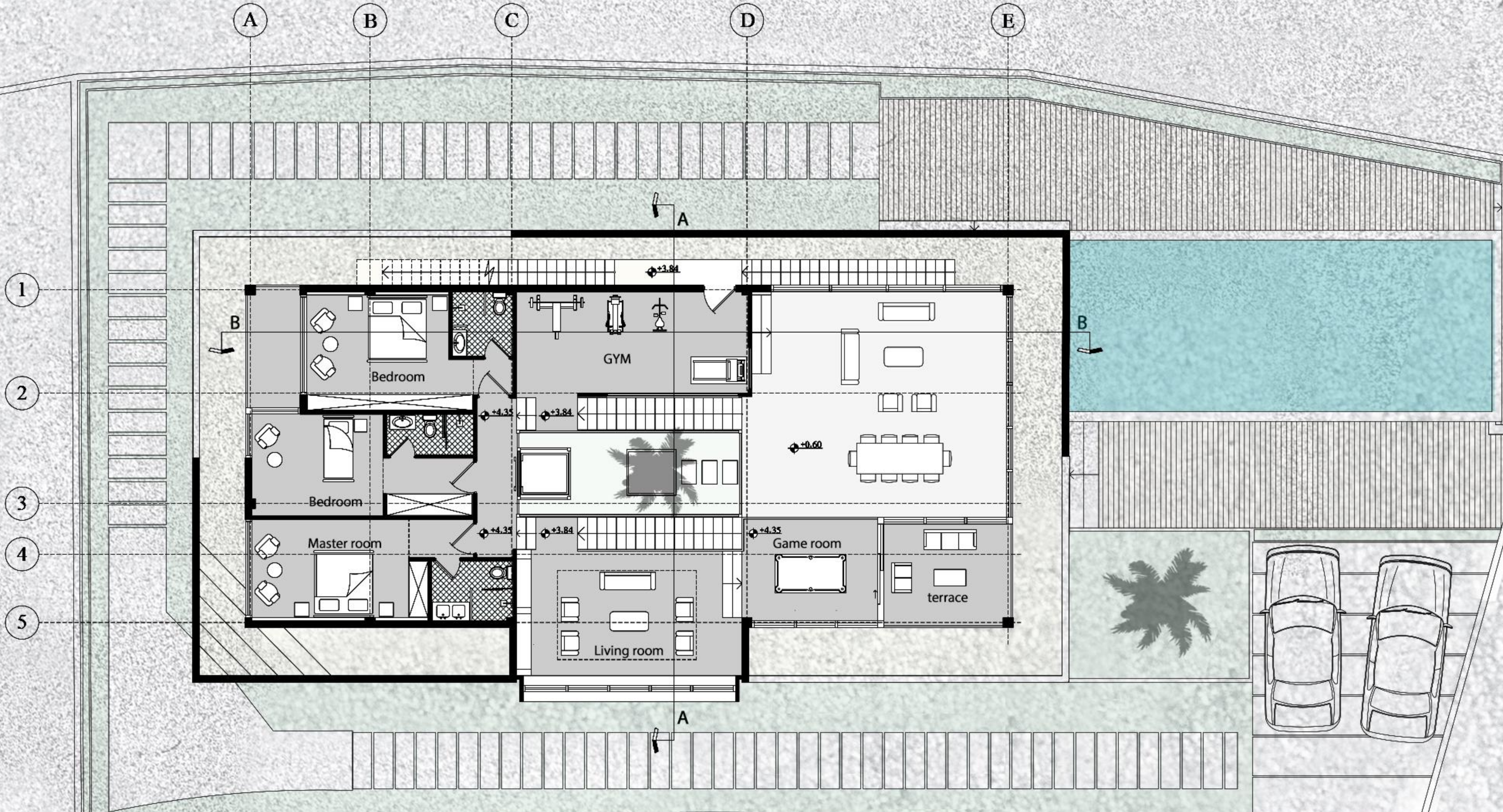



GROUND FLOOR
AREA: 260M²

SCALE : 1/100



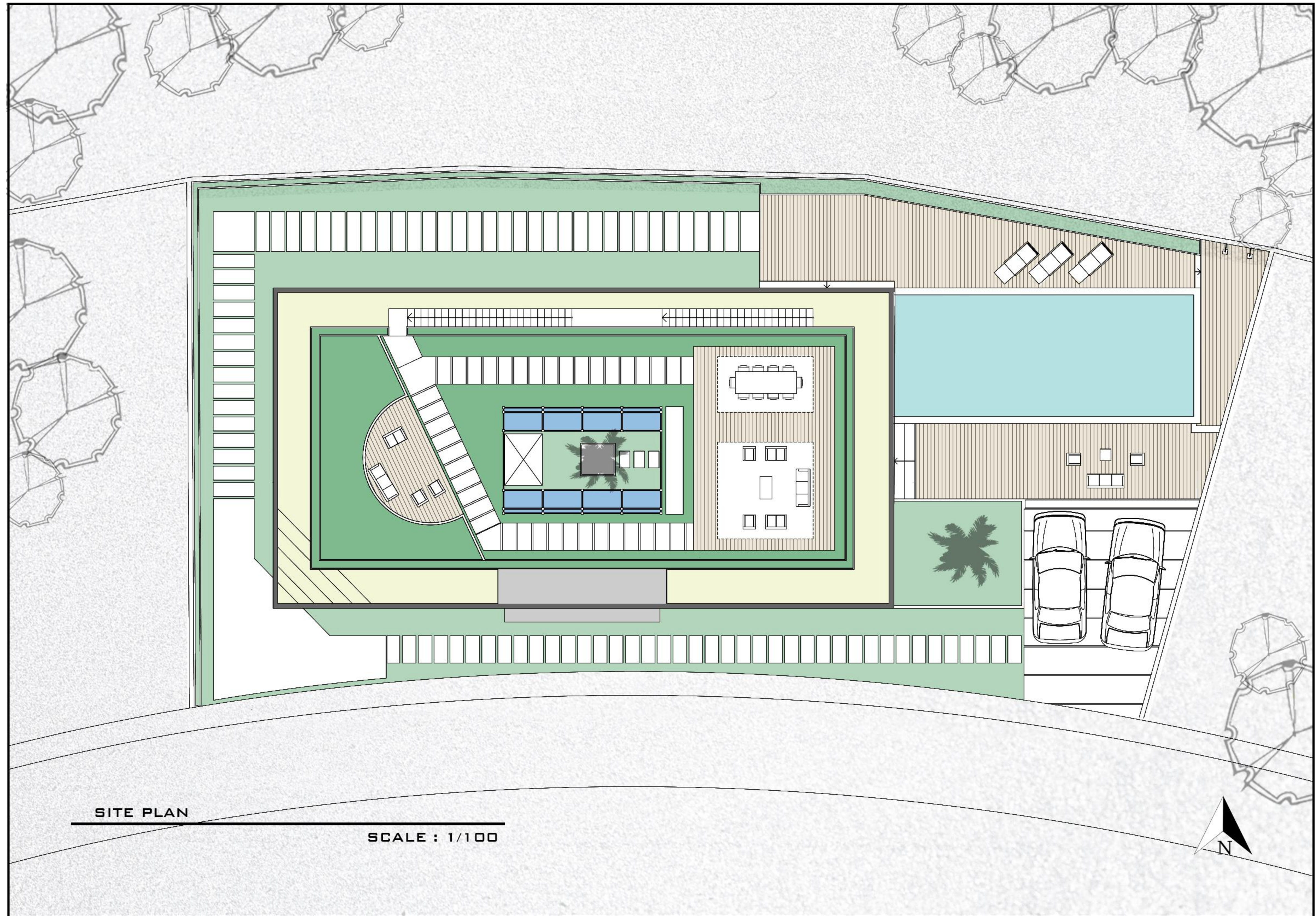

SITE PLAN

SCALE : 1/100



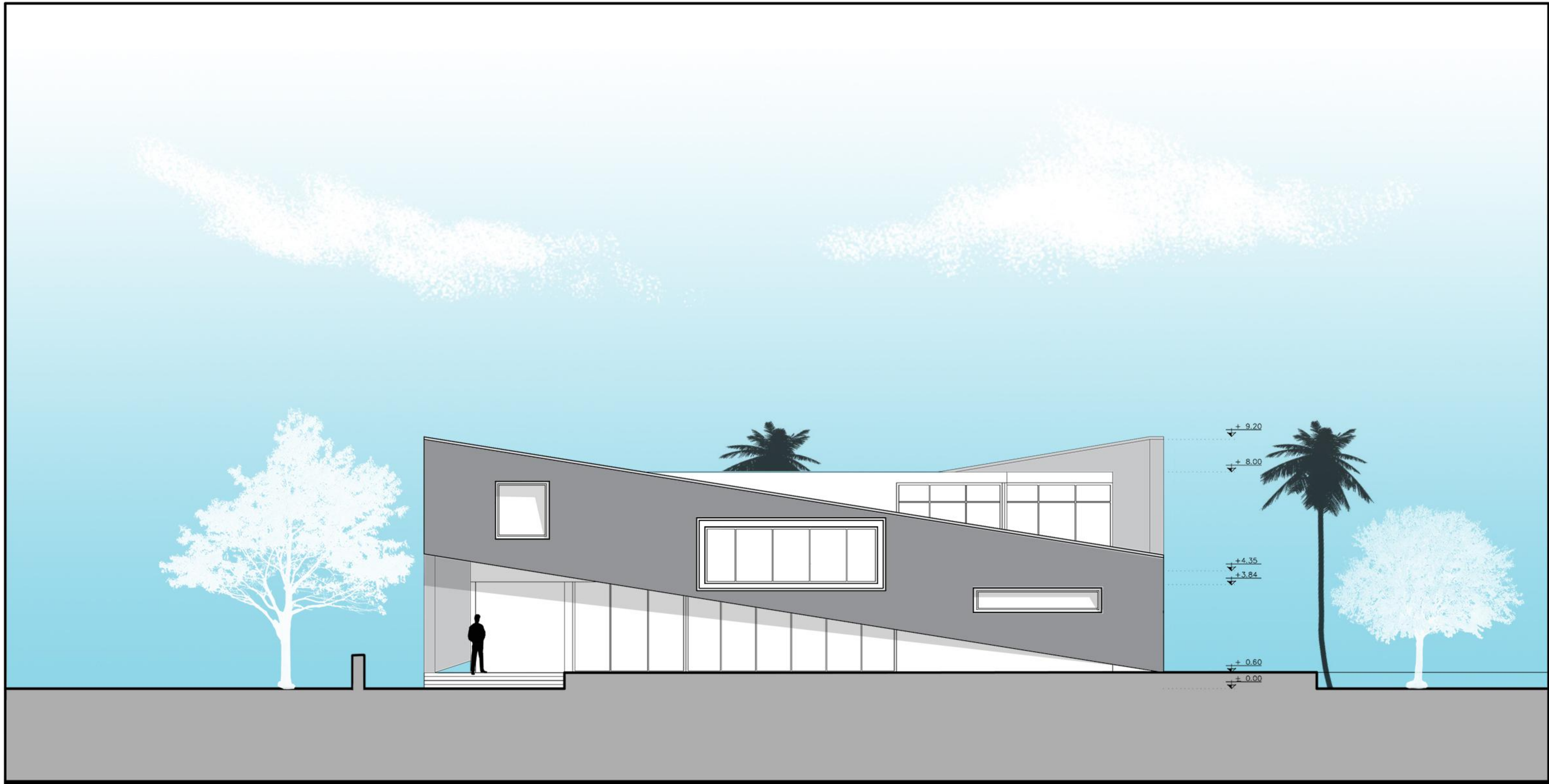

NORTH ELEVATION

SCALE : 1/100

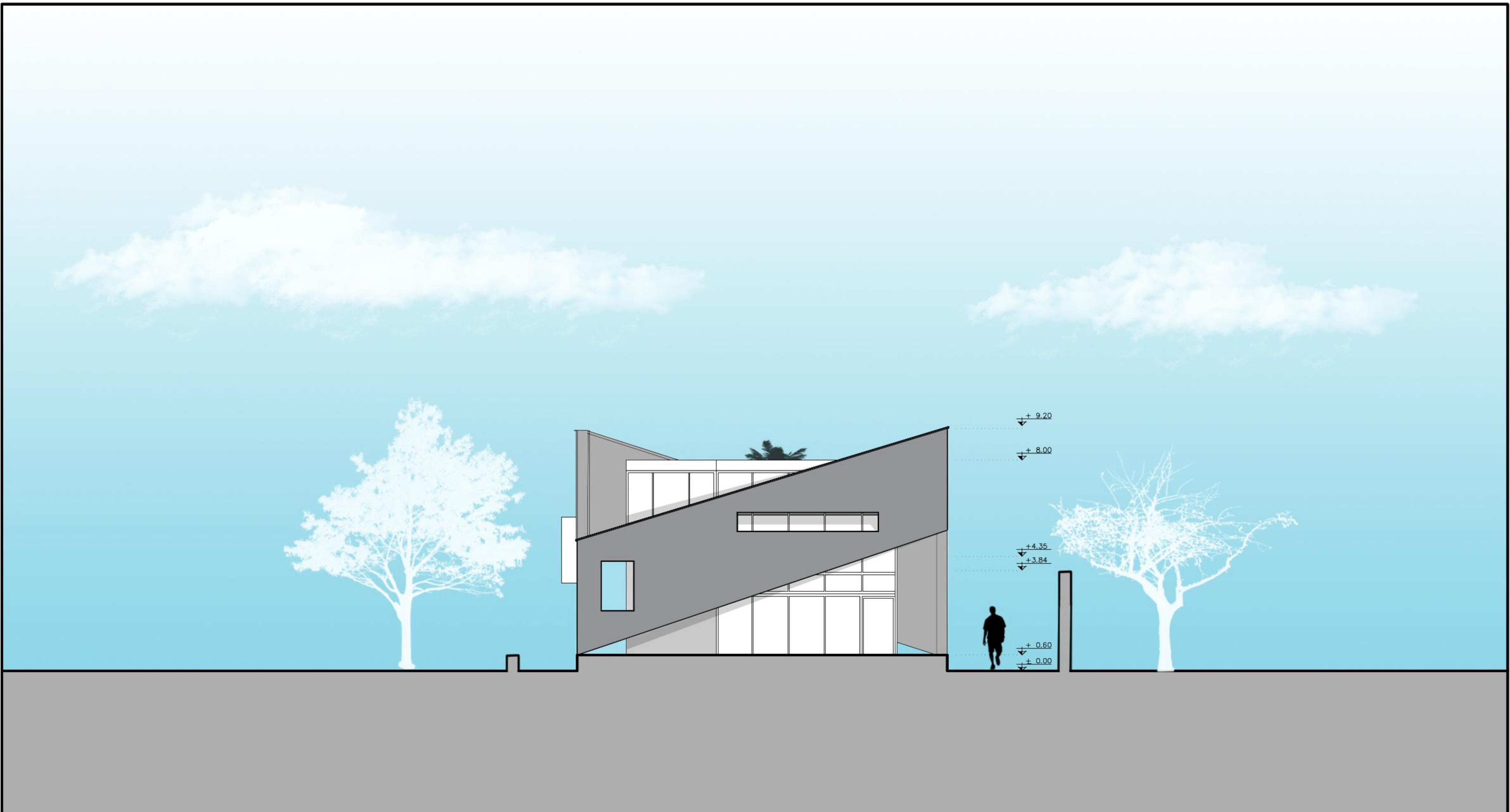

EAST ELEVATION

SCALE : 1/100

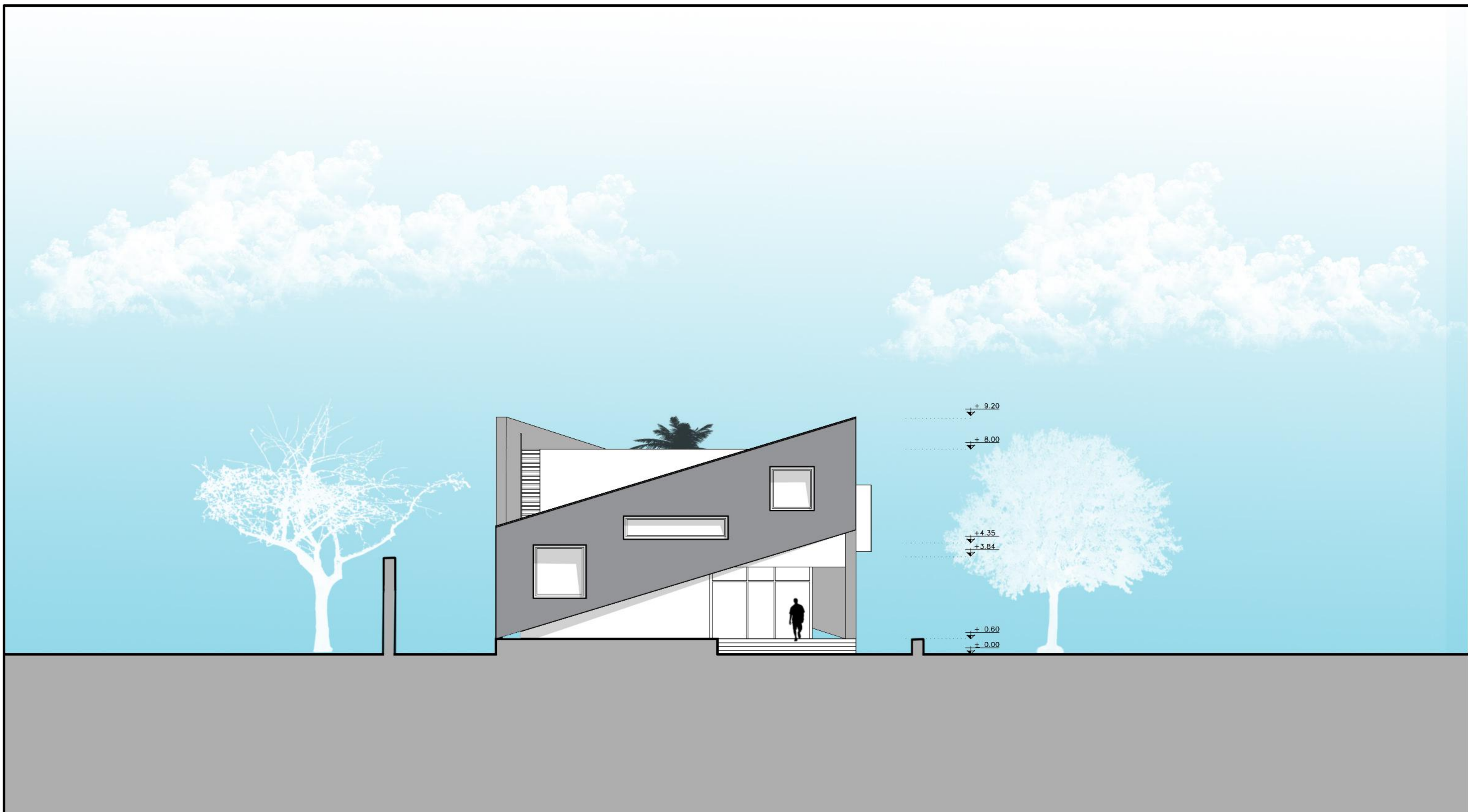

WESTE LEVATION

SCALE : 1/100

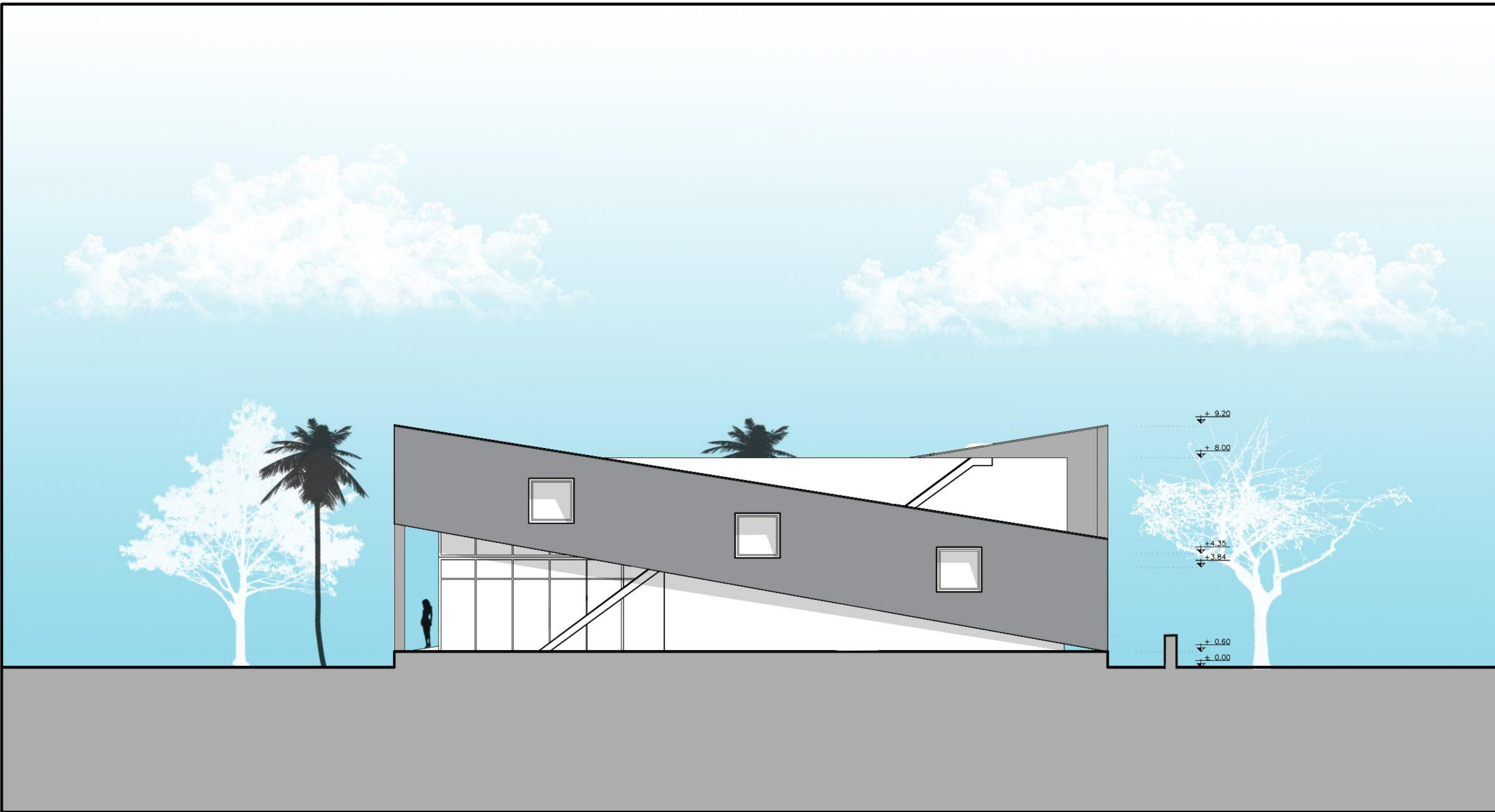

SOUTH ELEVATION

SCALE : 1/100

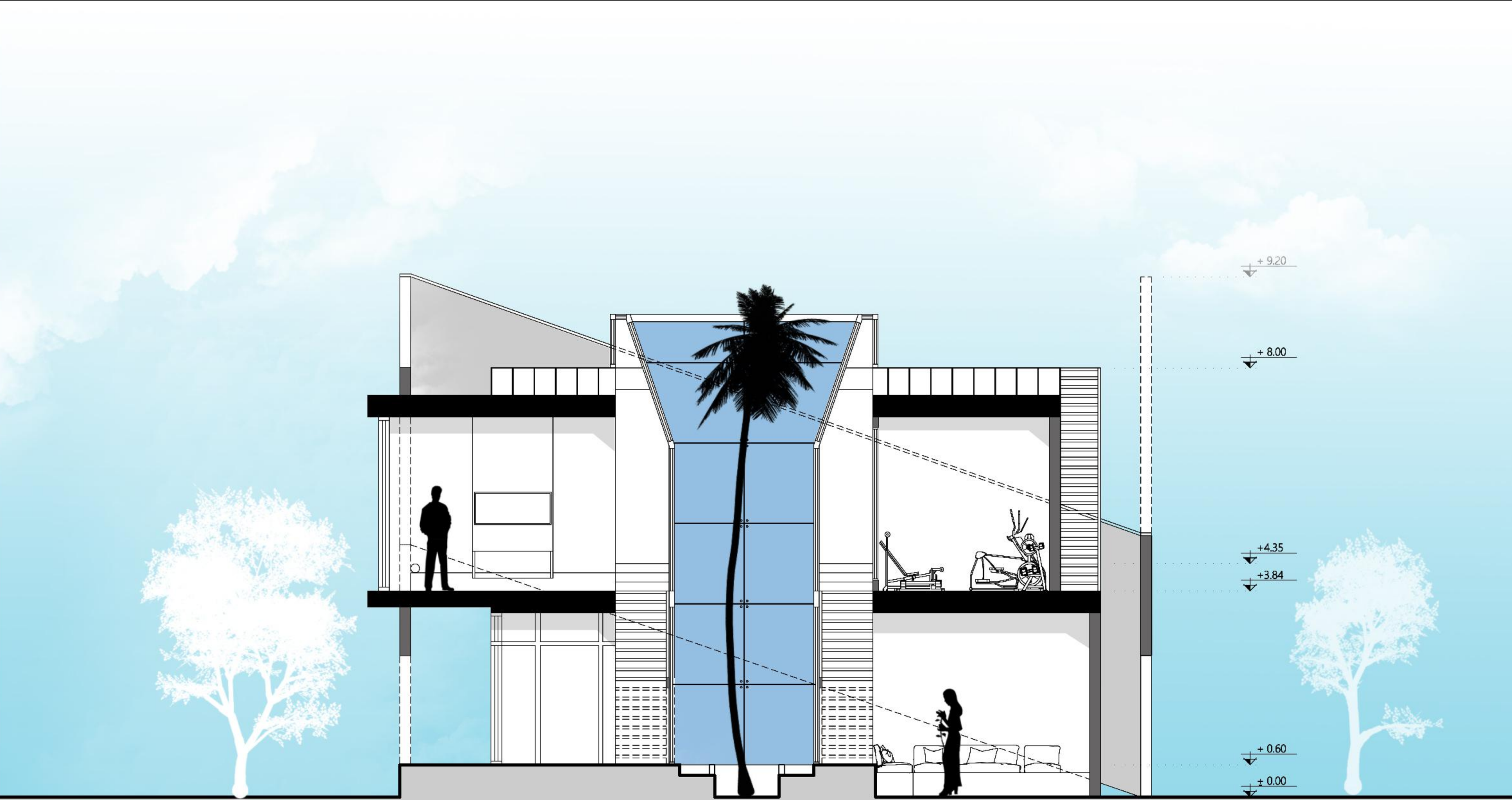

SECTION A-A

SCALE : 1/100



SECTION B-B

SCALE : 1/100

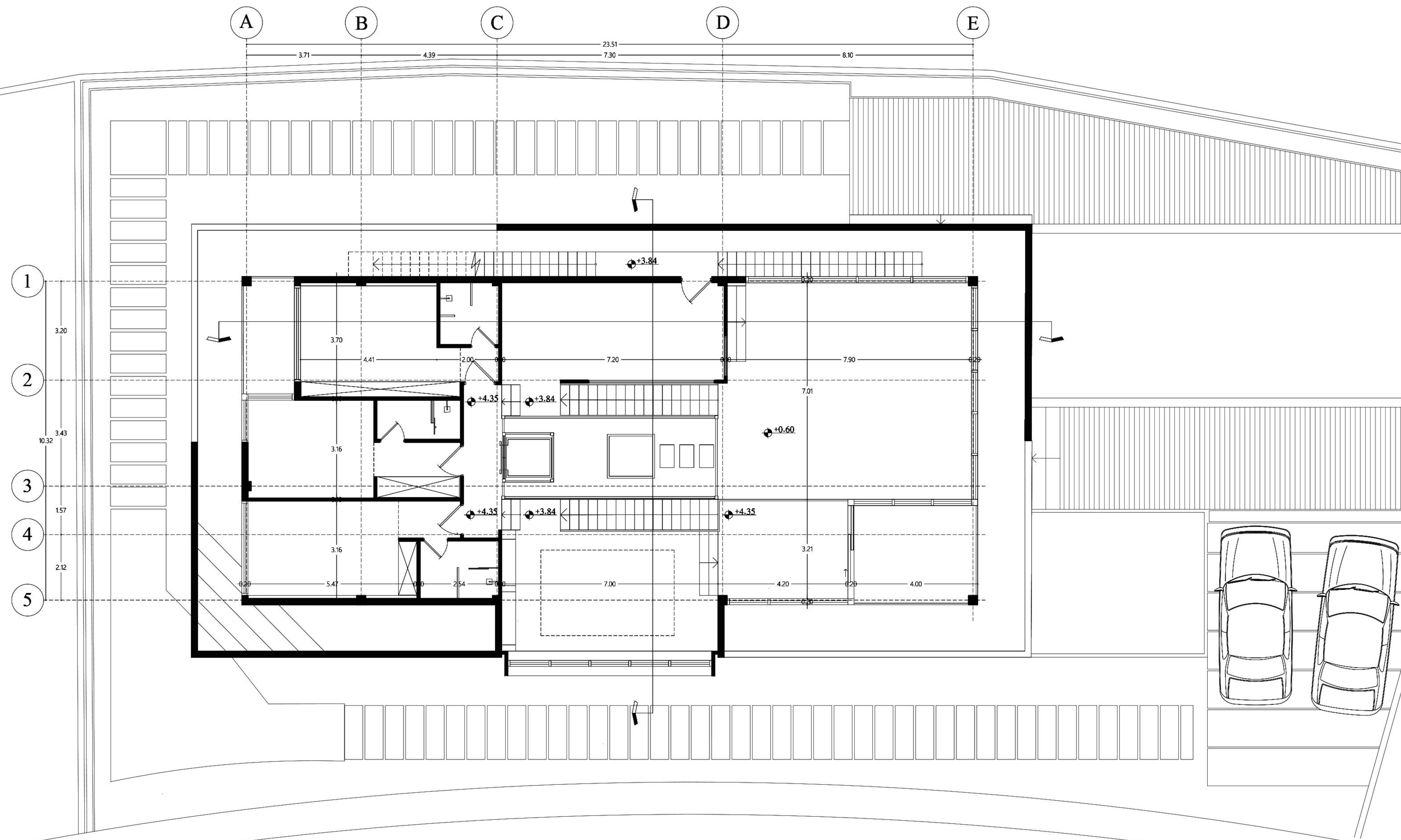

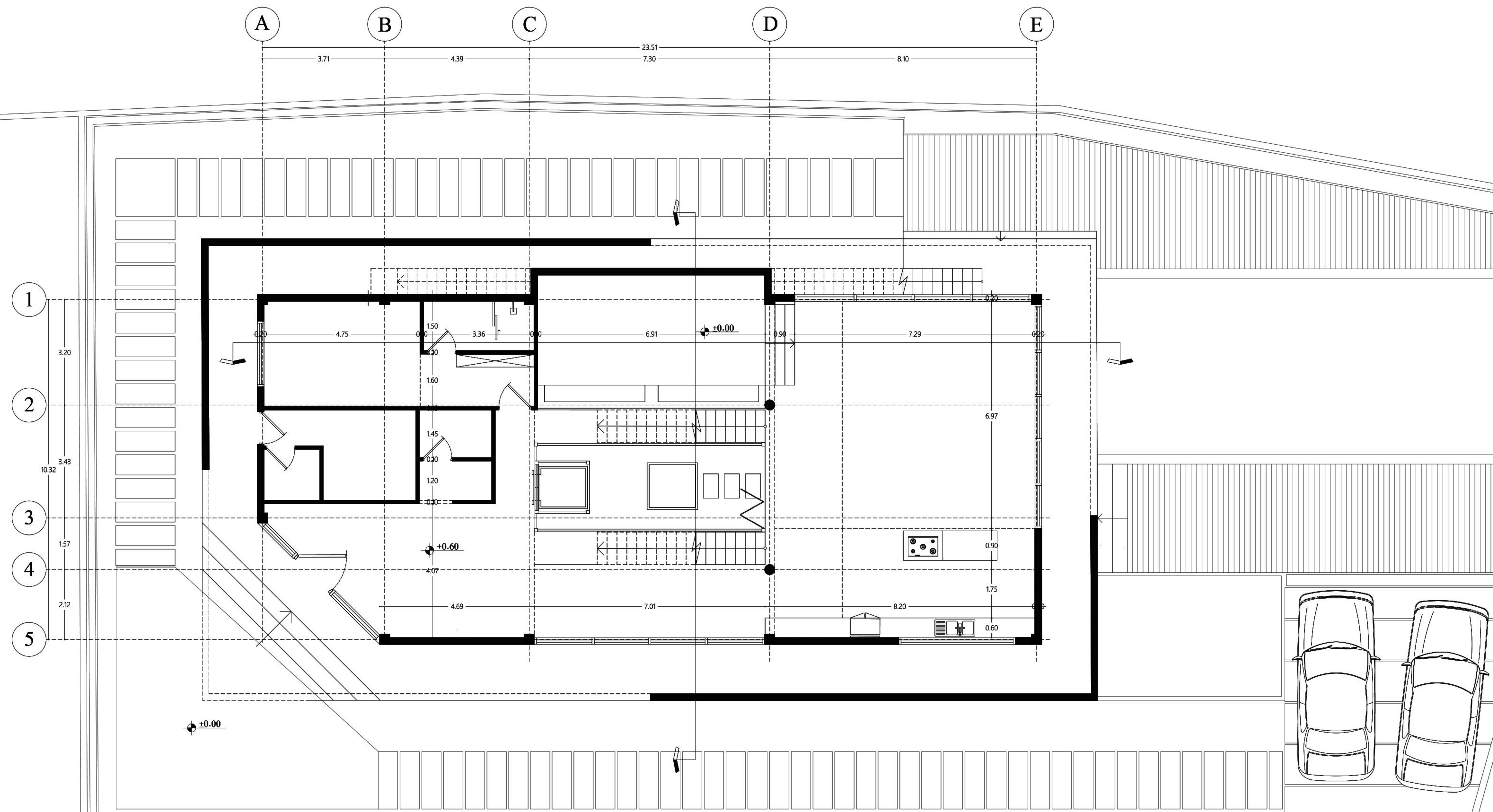

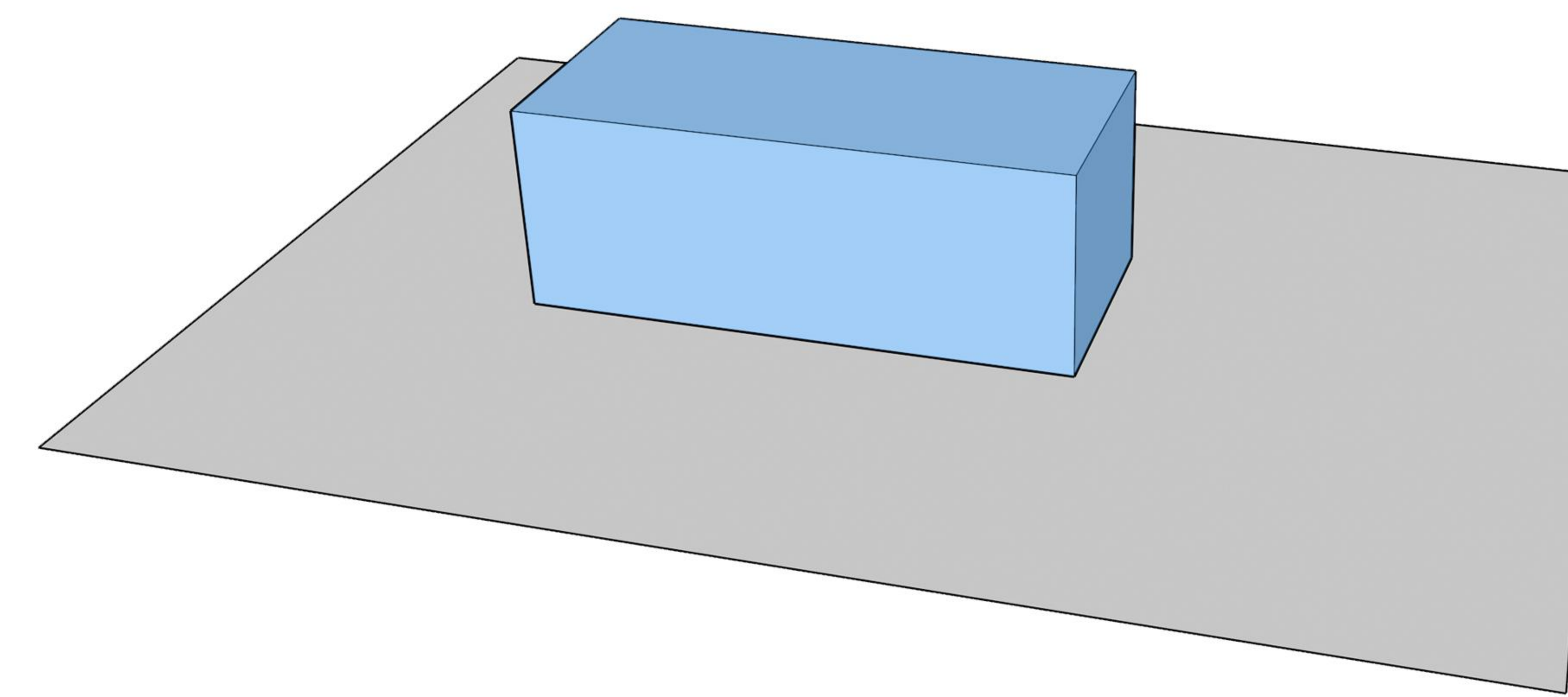

مرتفع کردن حجم شیشه ای به اندازه دو طبقه

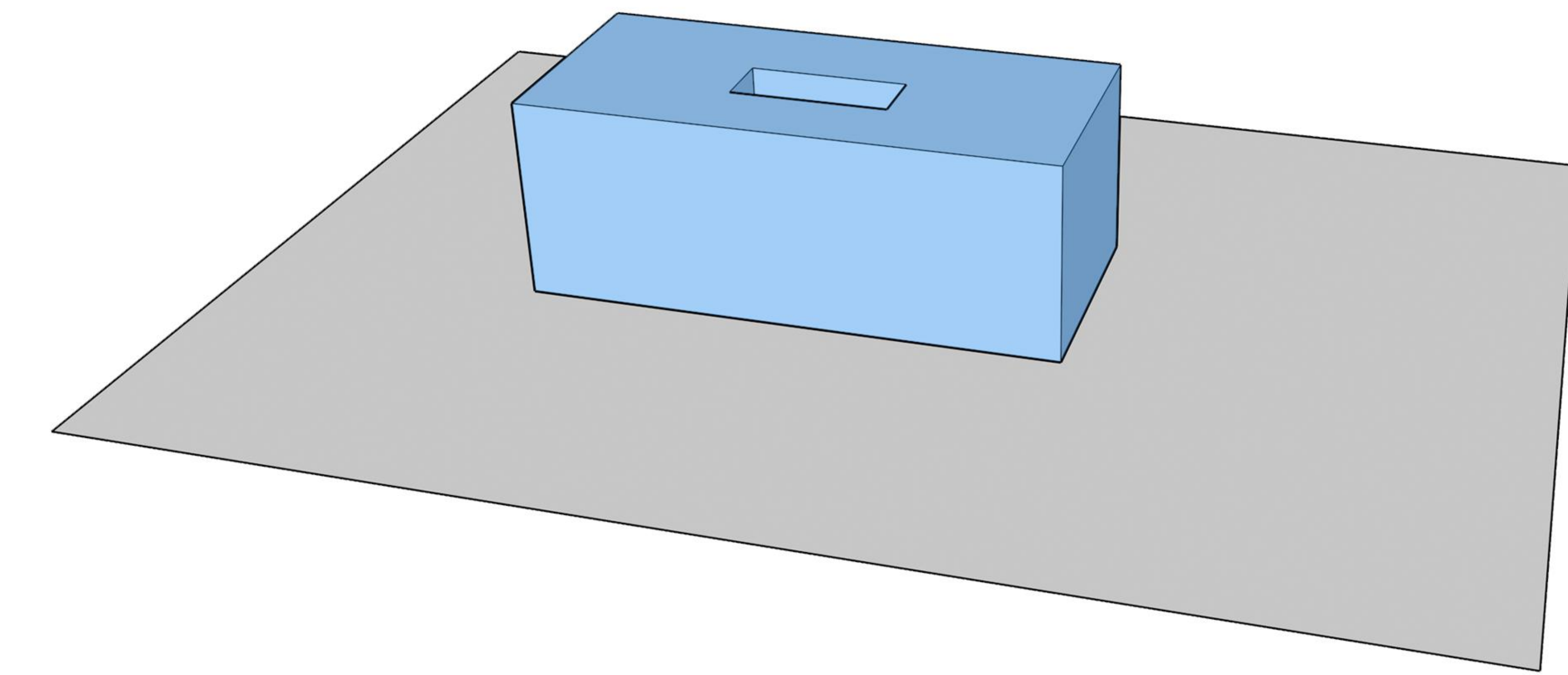

ایجاد حیاط مرکزی

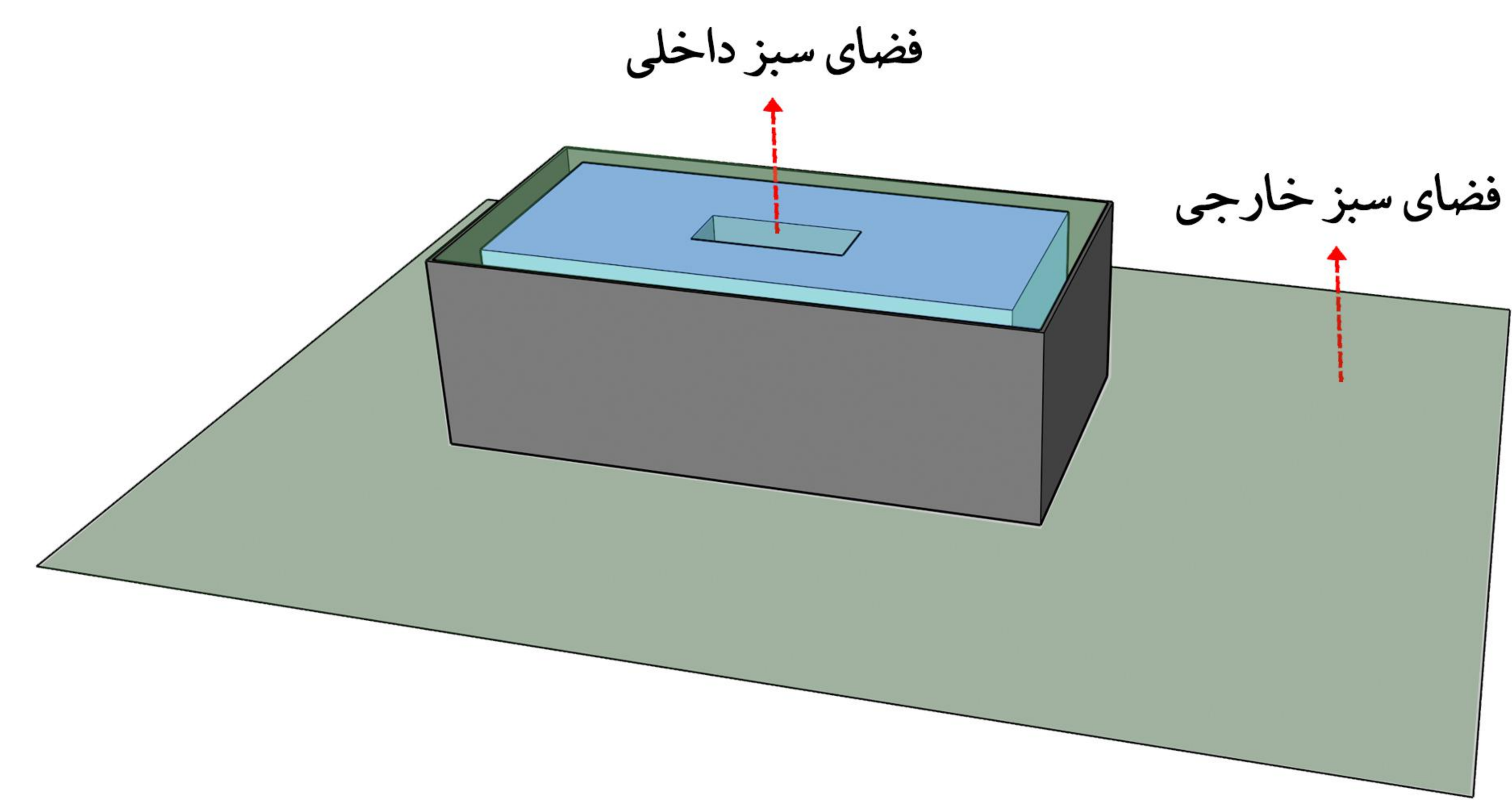
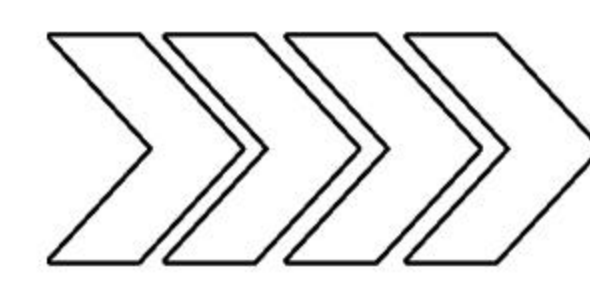

در نظر گرفتن پوسته ای در اطراف حجم شیشه ای برای ایجاد فضای بینابینی و ایجاد یک پیش ورودی برای فضاهای اصلی ویلا

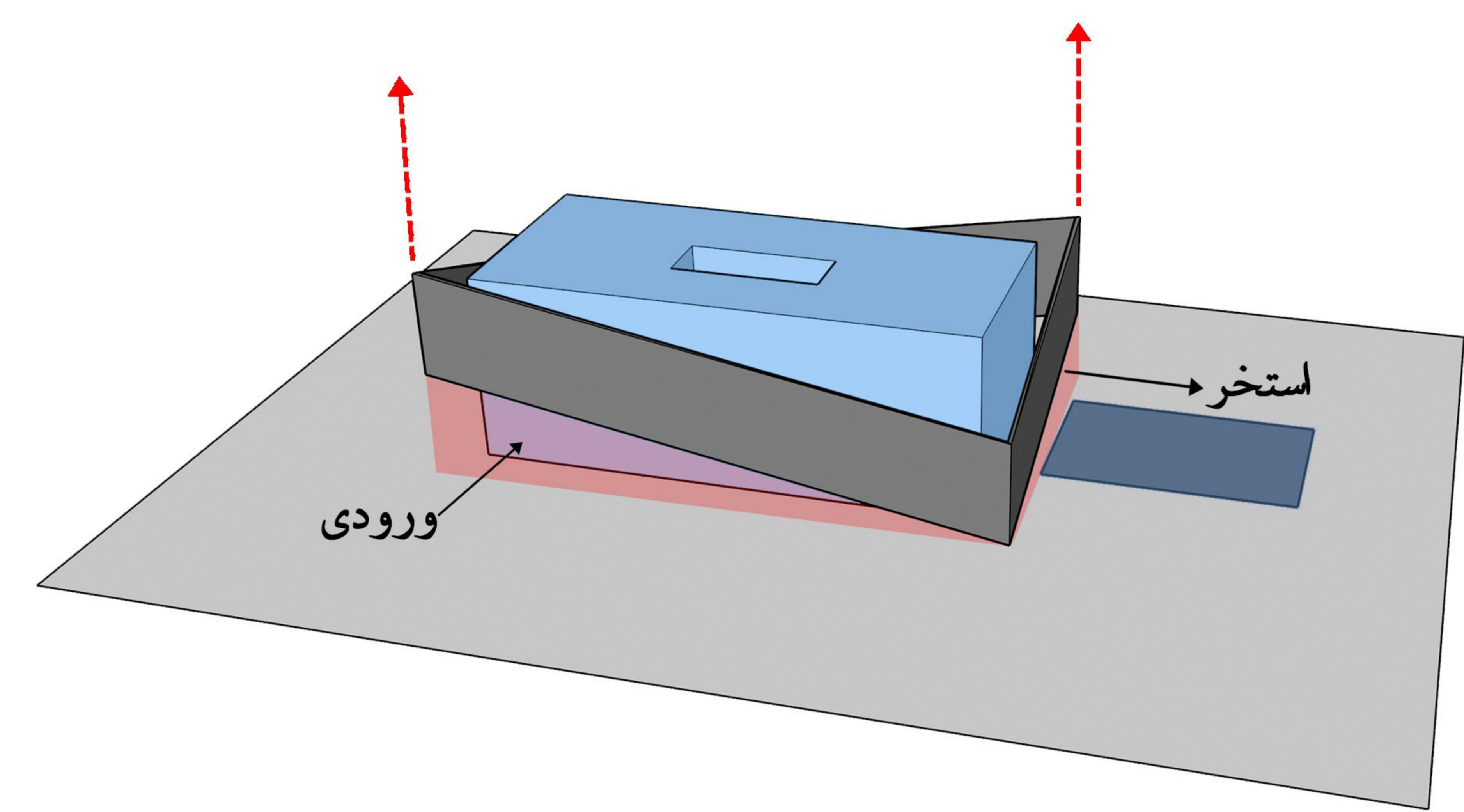
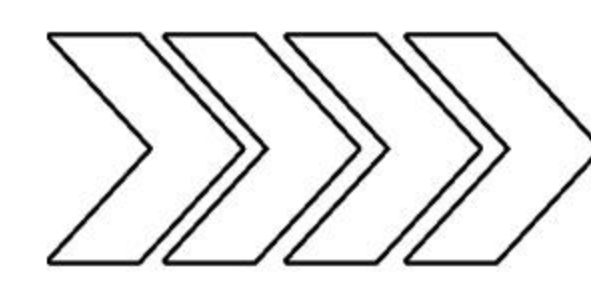

تغییر شکل پوسته به دلیل ایجاد ورودی و کنترل دید و منظر سایت و محل قرارگیری استخر

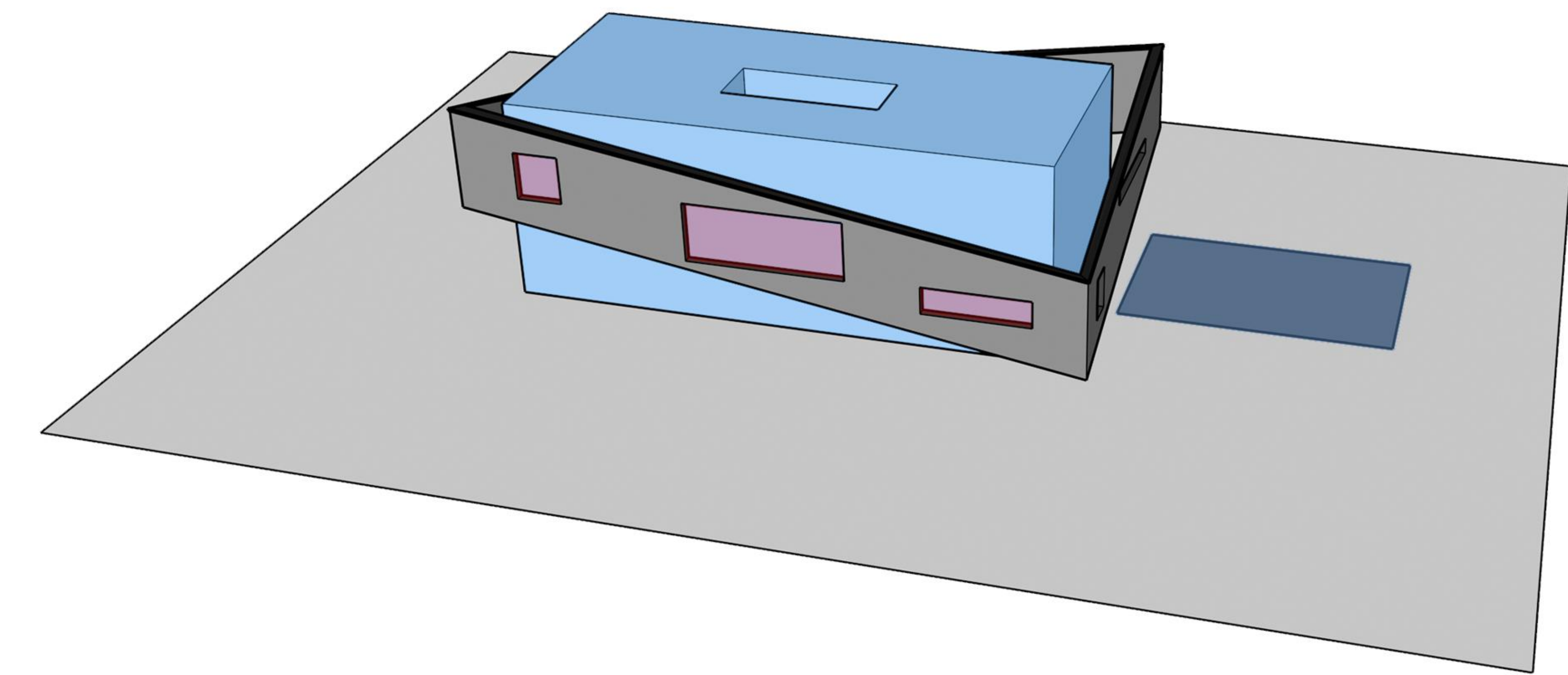

ایجاد حفره درون پوسته با توجه به قرارگیری فضاهای داخلی

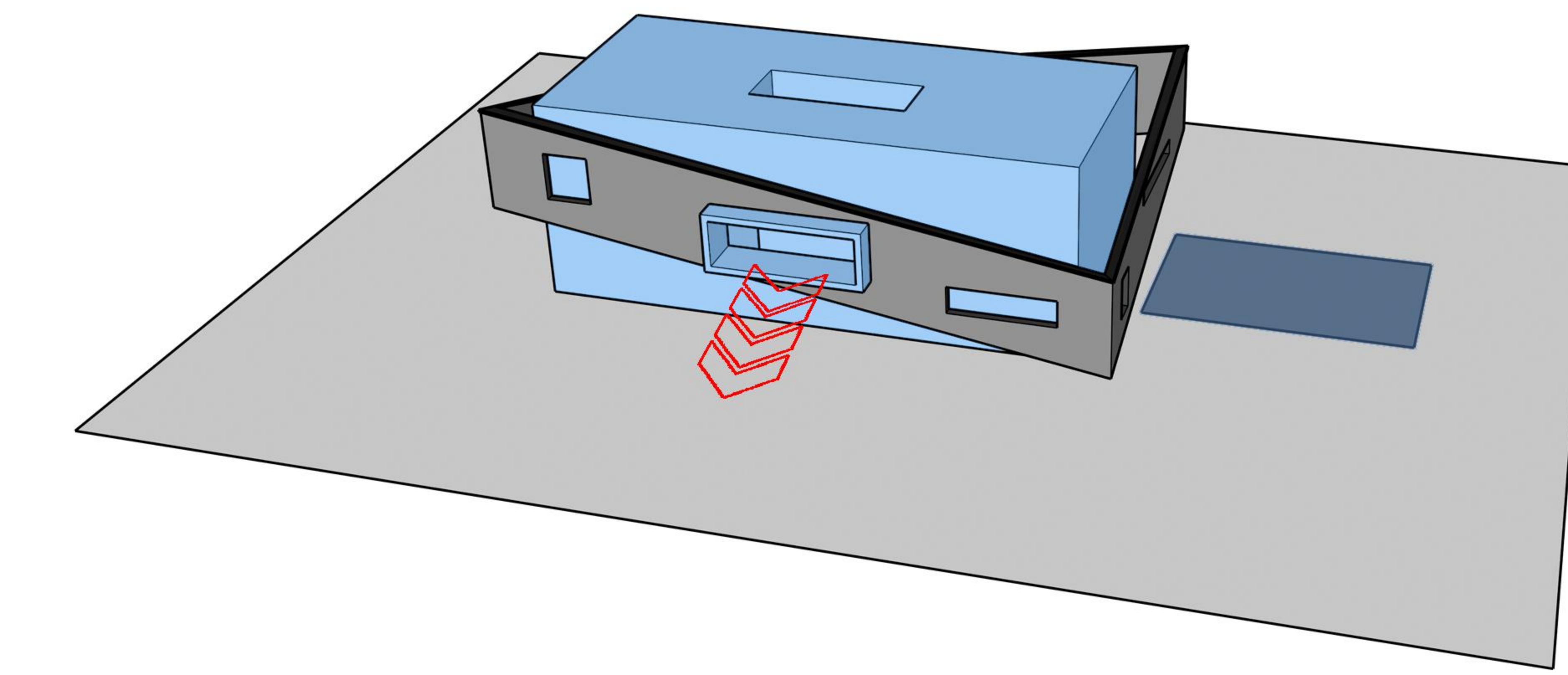

خارج شدن نشیمن از پوسته برای کنترل دید و منظر

